



AREAL

USER MANUAL



UPMIX  
ENGINE

## DISCLAIMER

### about this document

This manual provides information for the safe installation, operation, and maintenance of the Upmix Engine. It is intended for professional users such as:

- Audio Engineers
- System integrators
- Immersive installation
- Houses of worship, theatres, and cultural venues

### intended use

The Upmix Engine is a professional hardware DSP device intended exclusively for real-time audio upmixing in professional applications. Any use outside the specifications and recommendations described in this manual may result in unsafe operation or reduced performance, and may void the warranty.

### copyright and trademarks

Copyright © 2026 Areal BV and/or its affiliates. All rights reserved.

No part of this manual may be reproduced, stored, or transmitted in any form without prior written consent of Areal BV, except for internal training purposes.

The Upmix Engine and the Areal BV logo are either registered trademarks or trademarks of Areal BV in various countries. All other trademarks mentioned are the property of their respective owners and are used for identification purposes only.

### liability and changes

Areal BV has taken the utmost care in preparing this manual. However, Areal BV shall not be liable for any technical or editorial errors, omissions, or incidental or consequential damages arising from the use of this document or the product.



The information in this document is provided as is, without warranty of any kind, and is subject to change without notice.

Revision: v2.0

Release date: 8th May 2026

Copyright © 2026 Areal and/or its affiliates. All rights reserved.



 Storage temperature: -40°C to +70°C  
 Storage humidity: 5% to 95% RH  
 Storage atm. limits: 2000 m

PN: AUE25

AREAL BV  
Hoek 76 unit 200  
2850 Boom - Belgium 



# UPMIX ENGINE

## TABLE OF CONTENT

Disclaimer	2	User Instructions	17
Table of content	3	Setup Examples	24
Scope of delivery	4	Technical Specifications	28
Product Introduction	5	Safety & Symbols	29
Applications & User Groups	5	Troubleshooting	32
Upmixing explained	5	Maintenance, Cleaning & Disposal	32
Product overview	7	Regulatory & Compliance	33
Navigating the front panel touchscreen	10	Appendices	34
Installation	11	Contact	34



## SCOPE OF DELIVERY

### unboxing & inspection

Inspect the unit for damage upon receipt. If damaged, contact your distributor immediately.

1. Inspect the shipping carton and device for visible damage.
2. If damage is detected, immediately notify the carrier and your distributor.
3. Retain the original packaging materials for possible future transport.

### supplied items

The following items are included in the standard package:

- A 1x - Upmix Engine
- B 1x - Network cable, 3 m
- C 2x - Power cables (Neutrik Truecon, country-specific)

### not included

(optional, source externally)

- D-Sub break-out cable for connection of analog in- and outputs
- Cat5e/Cat6 cable for Dante™ or AVB networking
- 4x - rack screws with captive washers (to match the selected rack type)

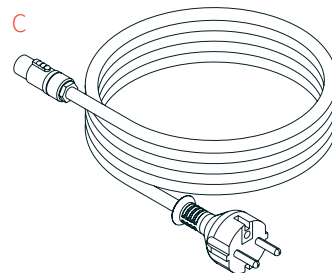
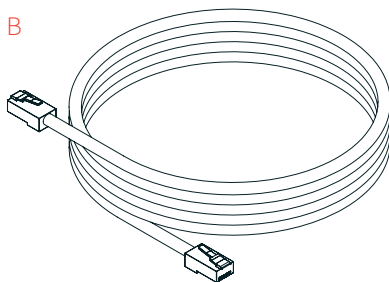
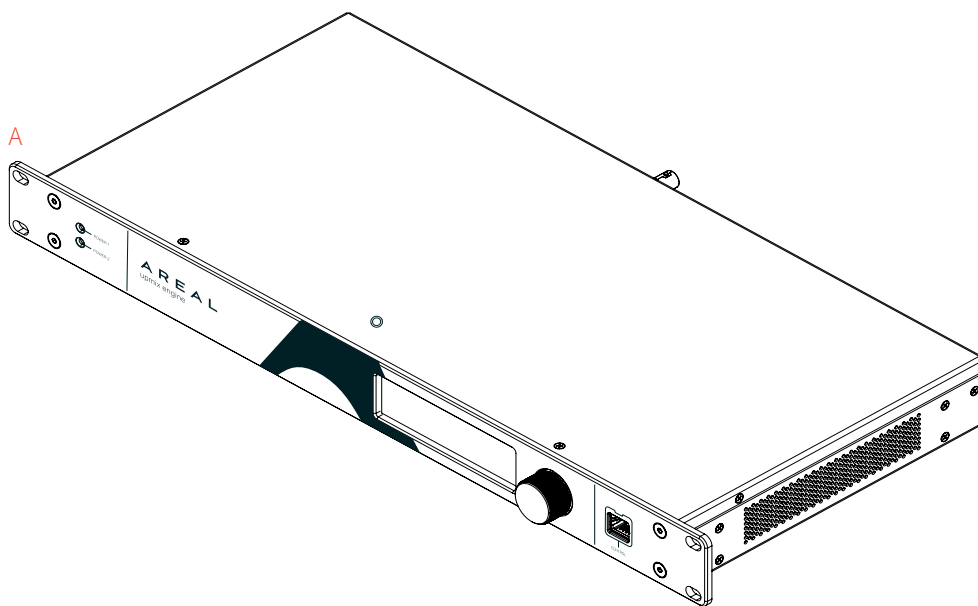

## PRODUCT INTRODUCTION

### general description

The Upmix Engine is a hardware DSP device that converts any stereo audio source into an immersive multichannel experience in real time.

Unlike object-based immersive processors, the Upmix Engine does not rely on individual audio objects or metadata. Powered by the proprietary RISE algorithm, it employs a real-time decorrelation process that redistributes stereo content into custom formats up to 12ch or up to 7.1.4 standard layout, without introducing artifacts or altering the original source material.

### key features

- Real-time stereo to immersive upmixing with low latency
- RISE Upmixing algorithm for natural spatial expansion
- LF Warp technology, for steering and controlling low frequency.
- FocusField control to define and steer the immersive image
- Up to 12 configurable outputs for layouts up to 7.1.4 or custom arrays
- Flexible connectivity: AES3, Balanced Analog, Dante™, MADI, and AVB\*
- Redundant power and network options for reliability
- 1 19" 1RU rackmount chassis with front-panel touchscreen and encoder
- Remote control via browser-based UI or OSC from any device

## APPLICATIONS & USER GROUPS

The Upmix Engine is designed for professional use in both live and installed sound environments. It enables audio professionals to transform stereo content into immersive multichannel soundscapes, suitable for a wide range of applications:

- **Live Events & Touring** – Real-time immersive audio shaped to match the event music style.
- **Live Venues** – Unlock the full potential of fixed immersive loudspeaker systems with consistent spatial imaging.
- **Corporate Events** – Elevate presentations, product launches, and conferences with rich, engaging soundscapes.
- **Broadcast** – Tailor immersive upmixing to fit any network or project, with pristine dialogue clarity.
- **Creative Installations** – Enhance museums, galleries, and experiential spaces with dynamic and enveloping audio.
- **Houses of Worship & Theatres** – Provide audiences with a natural and expansive listening experience without altering existing workflows.

## UPMIXING EXPLAINED

The Upmix Engine creates an immersive experience by separating a stereo mix into multiple decorrelated versions of the left and right channels.

These decorrelated signals are routed to several loudspeakers with overlapping coverage in the listening area. When combined at the listener's ears, the brain fuses them into a natural and convincing immersive image while preserving the complete musical information.

This is achieved without any loss or degradation of the original signal: when the decorrelated signals are recombined, they reconstruct the original waveform perfectly.



## main dsp cores

expanding width and depth of field

Depending on the selected main core(s), the stereo left and right channels are split into multiple decorrelated versions:

- **Quad Core:** Left and Right each split into A and B, for use with four loudspeakers.
- **Hexa Core:** Left and Right each split into A, B, and C, for use with six loudspeakers.
- **Octa Core:** Left and Right each split into A, B, C, and D, for use with eight loudspeakers.

For a coherent immersive image, all versions (A, B, C, D) must be reproduced simultaneously. Loudspeakers carrying these signals should provide overlapping coverage so the listener perceives them as a single, fused sound field.

## stereo and mono buses

routing options for precision and flexibility

In addition to the upmixed signals, the routing matrix of the Upmix Engine provides the ability to use mono and stereo buses as well, offering extended flexibility for sound design.

- The stereo bus can be used to blend the original stereo signal with the decorrelated upmixed signal, allowing precise control over the level of immersiveness while retaining elements of the original stereo image.
- The mono buses are typically used for dedicated subwoofer assignments or for routing to a center loudspeaker.

To ensure proper alignment, it is essential to use the stereo and mono buses provided by the Upmix Engine, as these signals are delay-compensated with the upmix core processing to prevent phase and timing issues.

## spatial dsp cores

adding height and dimension

In addition to the main cores, two or four spatial loudspeakers can be added to extend the immersive field into the third dimension. Depending on the selected spatial core, the stereo signal is decorrelated and distributed across multiple height channels:

- **Spatial Di** – for use with two height loudspeakers.
- **Spatial Quad** – for use with four height loudspeakers.

**NOTE** - The spatial channels can only process information from a stereo signal and will not reproduce any information from a mono source.

### Creative applications

The spatial cores can also be used to add depth or ambience in less critical parts of a mix. For example, sending these channels to rear or surround speakers can create a subtle yet engaging sense of space for background audio or atmospheric layers.

## advanced immersive controls

The Upmix Engine provides advanced tools to fine-tune the immersive sound field for any environment or application:

- **LF Warp** – A dedicated low-frequency shaping algorithm designed for sub-arcing applications. It optimizes bass distribution across large audience areas, ensuring consistent low-end impact and clarity throughout the immersive field. For more details, please see page 22.
- **FocusField** – A perceptual control that allows the immersive image to be steered between focused precision (for clear localization and intelligibility) and diffuse presence (for enveloping and atmospheric soundscapes). This enables the operator to adapt the listening experience to both content and venue. For more details, please see page 22.



## PRODUCT OVERVIEW



### front panel description

The front panel of the Upmix Engine provides both system control and visual feedback:

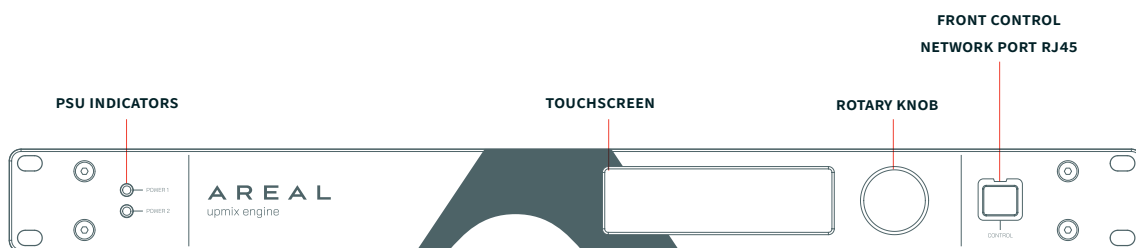

- **PSU Indicators** – Two LED indicators show the status of the redundant power supplies (Power 1 and Power 2). Both must be lit for full redundancy. A flashing LED indicates a failed or unconnected power supply.
- **Touchscreen** – Displays the home screen with system status and input metering, and provides access to all configuration menus.
- **Rotary Knob (Encoder)** – Used for navigation, parameter adjustment, and confirmation. Combined with the touchscreen, it allows full control of all device functions directly from the front panel.
- **RJ45 Network Port (Control)** – Provides a direct network connection for control via the Web UI or OSC protocol.



## rear panel description

The rear panel of the Upmix Engine provides all audio, network, and power connectivity:

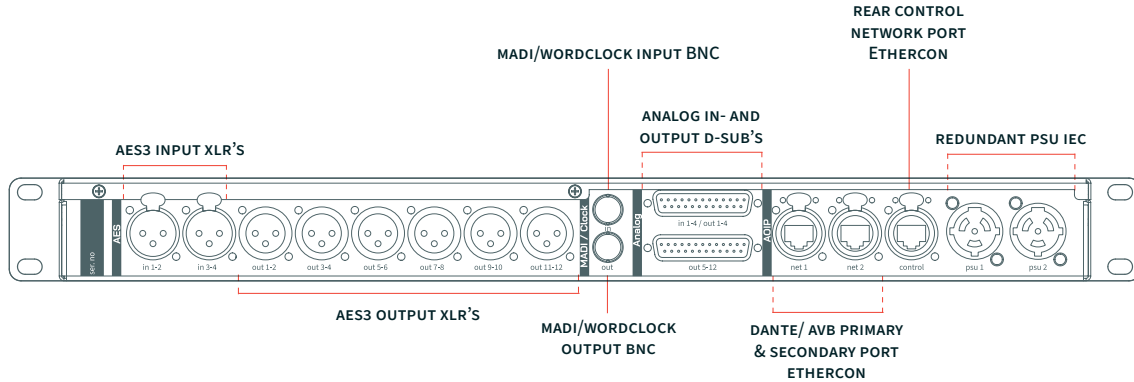

- **AES3 Digital I/O** – XLR connectors for AES3 input and output channels.
- **Balanced Analog Inputs and Outputs** – Line-level connections via D-sub connectors for analog interfacing.
- **MADI / Wordclock** – Two coaxial BNC connectors, configurable either as MADI input/output or as Wordclock input/output.
- **Network Audio Ports (Net 1 & Net 2)** – Two EtherCON connectors that can be configured for either Dante or AVB. Redundancy is available for both protocols. Dante and AVB cannot be used at the same time.
- **Control Network Port** – A dedicated EtherCON connector for control via the Web UI or OSC protocol, in addition to the RJ45 control port on the front panel.
- **Redundant PSU Connectors** – Two IEC inlets ensure secure power operation. For full redundancy, each inlet should be connected to an independent AC source.

**NOTE** - MADI and Wordclock cannot be used simultaneously.



## signal flow

Signal processing in the Upmix Engine is organized into the following stages:

- **Inputs** – Each audio interface (Analog, AES3, MADI, Dante™, or AVB) provides up to four input channels.
- **Pre-Matrix** – Incoming channels can be routed into the Pre-Matrix, where sources are assigned to the selected processing cores or auxiliary buses.
- **Processing Cores** – Depending on the chosen upmix mode (Quad, Hexa, Octa, Spatial Di, or Spatial Quad), the input source is decorrelated and expanded into multiple versions (A, B, C, D). In parallel, a dedicated Stereo Bus and two Mono Buses are available for flexible routing (e.g. center, subwoofers, or fills). All bus signals are latency-compensated to align with the upmix cores.
- **Post Matrix** – All core and bus outputs are collected in the Post Matrix, where they can be freely assigned to any of the twelve available output channels.
- **Output Processing** – Each of the twelve output channels passes through identical processing blocks: Focus/Diffuse, Parametric EQ, Gain, Delay, LF Warp, Polarity, and Mute.
- **Outputs** – The twelve output channels are made available simultaneously on all output interfaces (Analog, AES3, MADI, Dante™, AVB). The channel order is identical across all protocols.

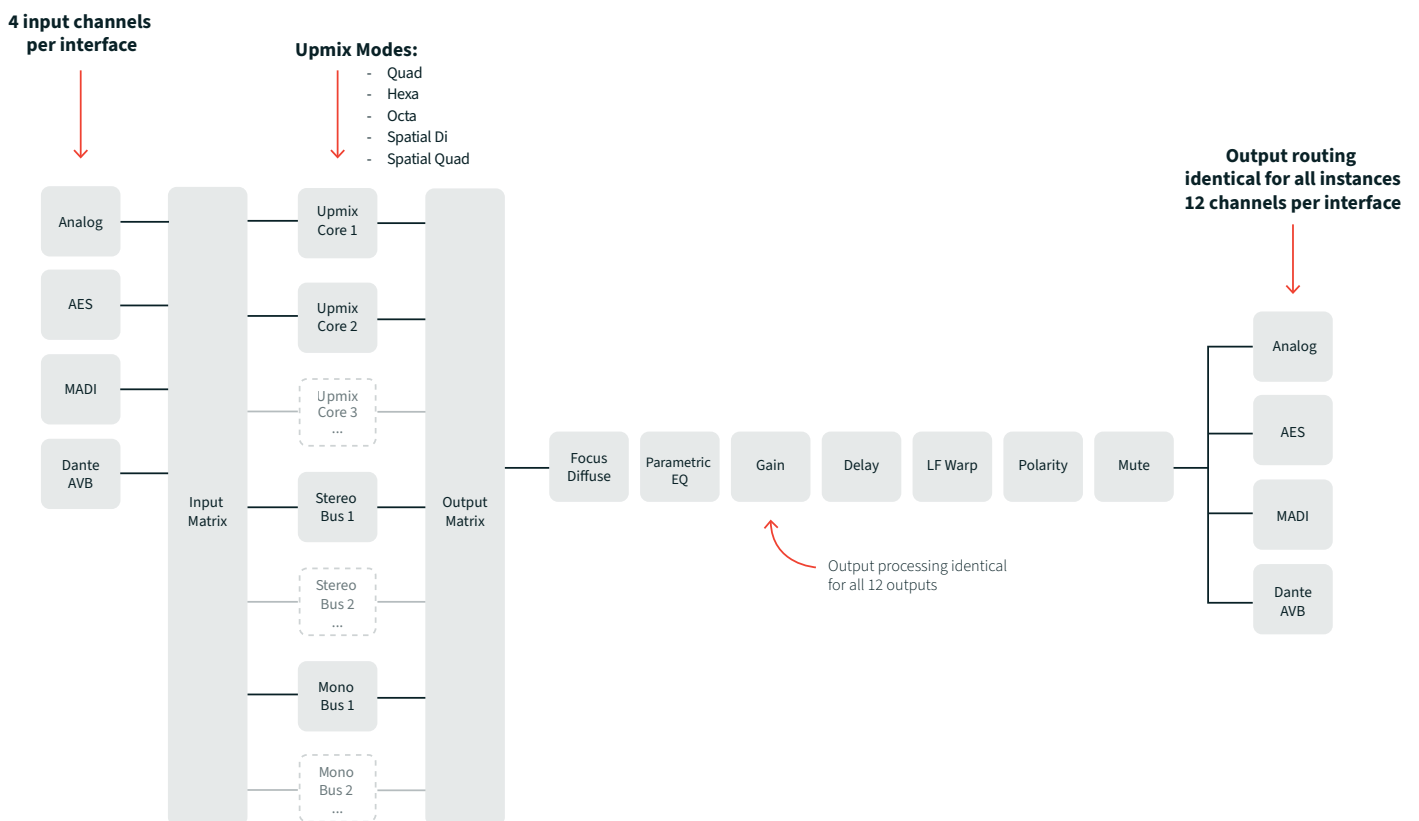

## NAVIGATING THE FRONT PANEL TOUCHSCREEN

The engine's front touchscreen allows to set-up and configure the device without the need for connecting a control device to access the GUI. All of the features that are accessible via the touchscreen are also available via the web interface.



### home screen

The touchscreen's home screen displays the device's active inputs and outputs. The input section consists of four panels (one for each Analog, Digital, AOIP, and Madi input interfaces) with four inputs each. The output panel displays the device's twelve outputs, which are all output simultaneously on all output interfaces.

Tapping the IP address alternates between the two IP ports.

Tapping on any of the input and output panels displays the level of the audio passing through each of the channels. Tapping again allows you to enable and disable mutes on all of the channels individually.

**STATUS OF THE REDUNDANT POWER SUPPLY**

**DEVICE'S CLOCKING STATUS**

**DEVICE'S TEMPERATURE**

PSU ●● 48 kHz ● Internal ● 45°C ●

**INPUT**

Analog	1	2	3	4	Digital	1	2	3	4
	●	●	●	●		●	●	●	●
Aoip	1	2	3	4	Madi	1	2	3	4
	●	●	●	●		●	●	●	●

**OUTPUT**

1	2	3	4	5	6
●	●	●	●	●	●
7	8	9	10	11	12
●	●	●	●	●	●

Home      Preset: [0\*] default 🔒      192.168.10.79

**CURRENT MENU TAB**      **NAME OF THE ACTIVE PRESET**      **IP ADDRESS**  
front and rear control ports



## main menu

Pushing on the rotary encoder enters the main menu. The home icon on the right returns to the home screen.

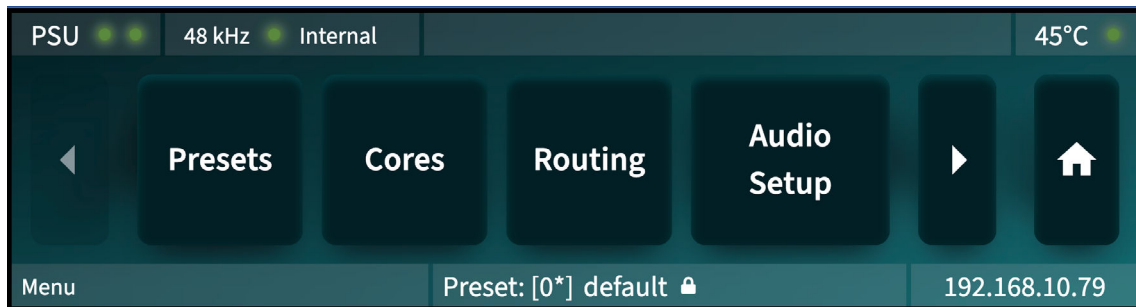

## flowchart

Navigating the menu follows the flowchart below:

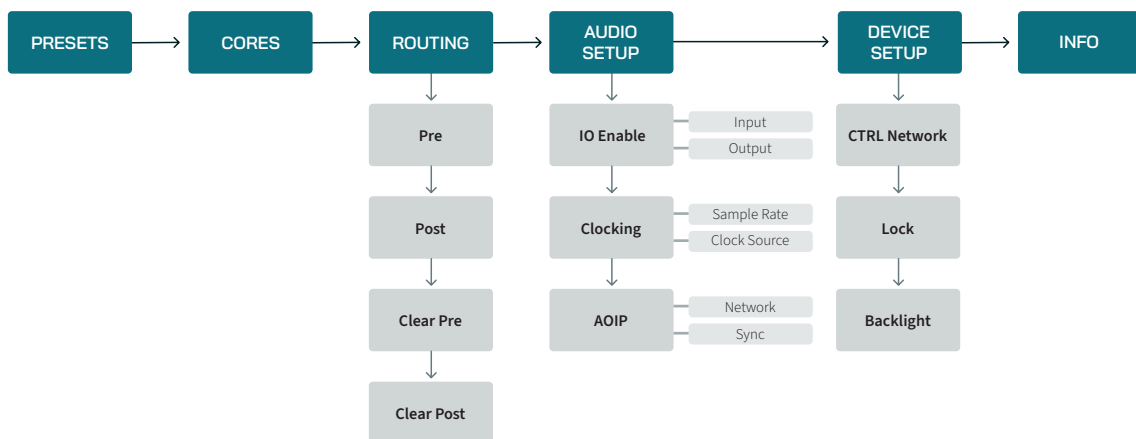

## PRESETS

The presets menu allows you to create new presets, as well as save them, recall them and edit them. Navigation through the presets can be done through the touchscreen or the rotary encoder



## CORES

The Cores menu allows the configurations of the processing cores that will be used. The "+" and "-" buttons below each cores names are used to add and remove cores from the configuration respectively

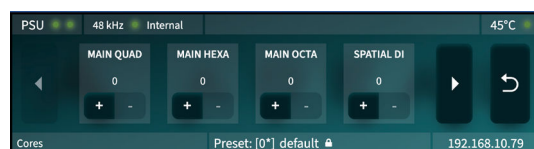

## ROUTING

Inside the Routing menu you can assign inputs to the cores selected via the Pre submenu, and assign the upmixed outputs of said cores to the engine's outputs via the Post submenu. Two buttons for clearing the pre-matrix (Clear Pre) and post-matrix (Clear Post)

### Pre Tab

When entering the Pre tab the cores that you selected in the previous menu appear. By selecting each one of them, you can assign the inputs of each interface to the left and right inputs of the core. The input interface is displayed at the left side of the screen and the arrows below the name allow for alternating between them.

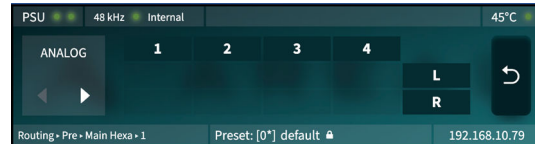

### Post Tab

The post tab displays the cores selected. When selecting one of the cores you can assign the outputs of each core to the twelve outputs of the upmix engine. The arrows on the left allow for scrolling between each core's outputs, while the arrows on the right allow for scrolling between the engine's outputs.

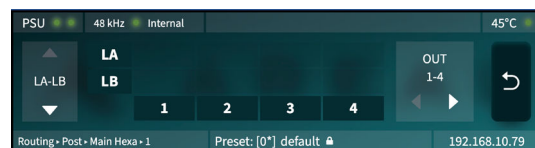

### Clear Pre and Clear Post

The Clear Pre and Clear Post buttons allow you to clear all configurations in the pre and post matrix respectively. If there are active routings a pop-up will notify the user.

## AUDIO SETUP

### IO Enable

The IO Enable tab allows you to enable the interfaces that you want to use, and disable the ones you are not using. By disabling the interfaces you are not using the matrixes will only display the relevant information and the interface is kept clean.

### AOIP

In the AOIP tab you can switch the network mode between switched and redundant. Switching it reboots the module. You can also set a manual IP address for both network ports or set them to DHCP.

### Clocking

The Clocking tab allows you to set the sample rate in which the Upmix Engine operates and the source in which the engine clocks to. The engine can either be a clock master or follower.

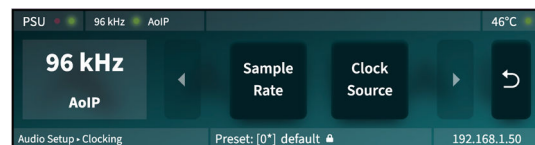

## DEVICE SETUP

The Device Setup tab allows you to set a manual IP address for both control ports or set them to DHCP. You can also lock the device's screen and set the screen's backlight by rotating the encoder.



## INFO

The Info tab displays information about the device's serial number, firmware and hardware version etc.

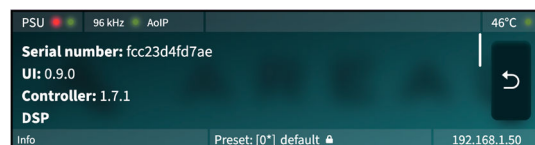

## INSTALLATION



### IMPORTANT SAFETY NOTES

- Only qualified personnel may install the Upmix Engine.
- Use only the supplied neutrik truecon power cables and ensure the device is properly grounded.

### rack installation & dimensions

- The unit is 1U high and designed for installation in a standard 19" EIA rack.
- Secure the device in the rack using four rack screws with captive washers that are compatible with your specific rack type (screws are not included with the device) Tighten screws firmly but avoid overtightening to prevent damage to the rack ears.
- Weight: approx. 3.5 kg (7.72 lbs).
- Dimensions (W × D × H): 482 × 220 × 44 mm.
- Installation depth: 220 mm (without connectors). Allow an additional 70 mm clearance at the rear for cabling.

### OUTLINE DRAWING



## ventilation

This device uses a left-to-right airflow design, which differs from the typical front-to-rear cooling. To ensure reliable operation:

- Maintain at least 5cm (2in) of clearance on both the left (air intake) and right (air exhaust) sides.
- Do not obstruct the ventilation grills.
- When multiple units are mounted on top of each other, monitor temperature levels for reliable operation.
- Ambient operating temperature: -20 - 40 °C, fan-cooled.
- The unit's internal temperature can be monitored via the web interface under the Info tab.

## power supply and grounding

The Upmix Engine is equipped with two internal redundant power supply units (PSUs) to ensure maximum reliability. For full redundancy, connect PSU1 and PSU2 each to an independent AC power source. If only one PSU is connected, the unit will continue to operate, but without redundancy.

Use only the supplied Neutrik Truecon power cables and always connect the unit to a properly grounded outlet. The mains rating is 100–240 V AC, 50/60 Hz, with a maximum consumption of 100 W. Typical consumption is less than 28 W per PSU. Ensure that the AC supply can deliver sufficient current without overloading.

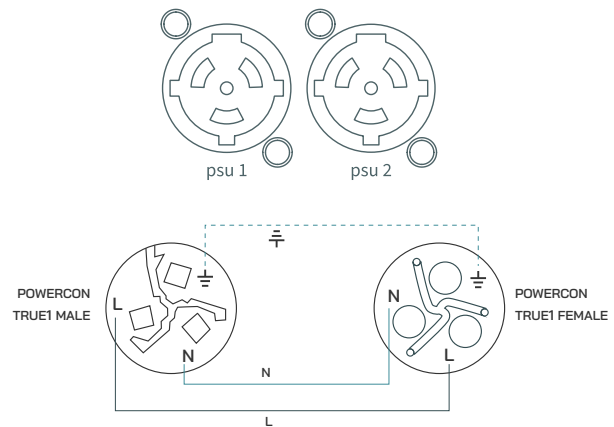

### ⚠ IMPORTANT INSTALLATION NOTES

- Do not use extension cords, multi-socket adapters, or power strips.
- The mains outlet must remain accessible at all times to allow quick disconnection in case of emergency.
- Protect the unit against liquid spills, excessive dust, and extreme temperatures.
- Disconnect both power cables before cleaning, servicing, or moving the unit.
- Only qualified service personnel are authorized to open or repair the device.

On the front panel, two LEDs labeled Power 1 and Power 2 indicate the status of the power supplies

- **LED on** = PSU is active and operating normally.
- **LED flashing** = PSU not connected or inactive.
- For full redundancy, both LEDs must be illuminated.



## control network

The Upmix Engine provides two options for control network connection: an RJ45 port on the front panel and an EtherCON port on the rear panel. Either port can be used to connect the unit to the control network.

Control is available via the web-based UI or through OSC commands.

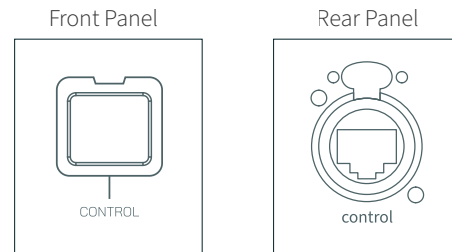

## RJ45 Wiring and Pinout

When connected to an active network, the yellow LINK LED illuminates. Data transmission is indicated by the green ACT LED, which may flicker continuously or intermittently.

Pin no.	Color	Color
1	White / Orange	TP1+
2	Orange	TP1-
3	White / Green	TP2+
4	Blue	TP3-
5	White / Blue	TP3+
6	Green	TP2-
7	White / Brown	TP4+
8	Brown	TP4-

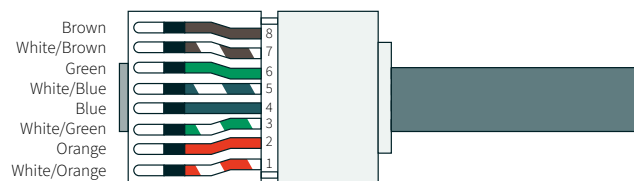

## audio connection

The Upmix Engine provides both digital and analog audio I/O. Each format supports up to four input channels and twelve output channels. All connectors are located on the rear panel.

- **Analog I/O** – Two 25-pin D-Sub connectors (Tascam pinout), providing 4 inputs and 12 outputs.
- **AES3 I/O** – Two XLR female connectors for 4 input channels and six XLR male connectors for 12 output channels.
- **Dante™ / AVB** – Two EtherCON ports (Net 1 and Net 2), configurable for Dante™ or AVB operation.
- **MADI / Word Clock** – Two BNC connectors, configurable either for MADI I/O or Word Clock I/O.

## analog

Balanced analog I/O is provided on the rear panel via two 25-pin D-Sub connectors (Tascam pinout). A breakout cable is required to interface with individual XLR or TRS connectors. The engine supports four inputs and twelve outputs. Refer to the pinout diagram for wiring details.

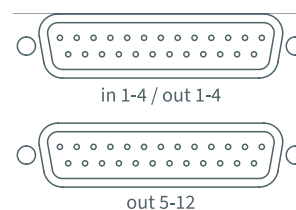

### DB25 IN 1-4, OUT 1-4

CH	+ Hot	- Cold	Ground
1- IN 1	24	12	25
2- IN 2	10	23	11
3- IN 3	21	9	22
4- IN 4	7	20	8
5- OUT 1	18	6	19
6- OUT 2	4	17	5
7- OUT 3	15	3	16
8- OUT 4	1	14	2

### DB25 OUT 5-12

CH	+ Hot	- Cold	Ground
1- OUT 5	24	12	25
2- OUT 6	10	23	11
3- OUT 7	21	9	22
4- OUT 8	7	20	8
5- OUT 9	18	6	19
6- OUT 10	4	17	5
7- OUT 11	15	3	16
8- OUT 12	1	14	2

Hot and Cold max 10V

### TASCAM PINOUT

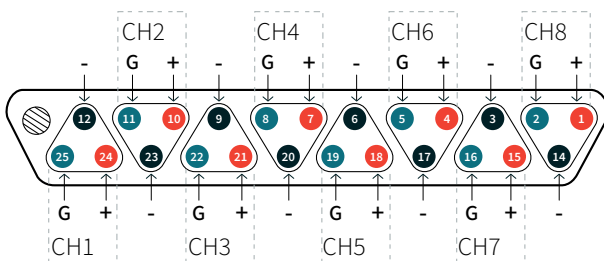

### XLR PINOUT

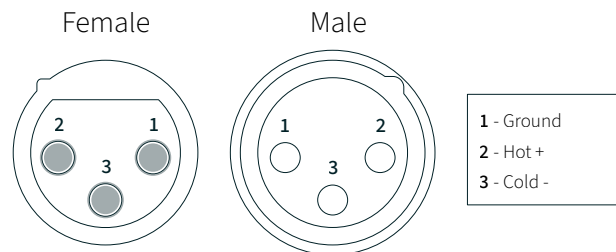

Pinout for Female Connectors (on rear side of upmix engine)

### AES3/EBU

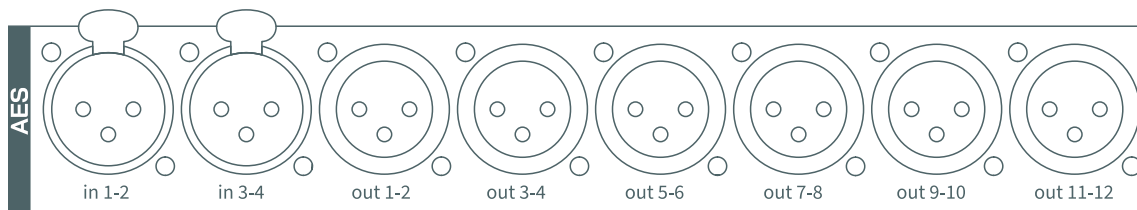

AES3/EBU digital I/O is available via eight XLR connectors.

- Two female XLR connectors provide four input channels (or two stereo pairs).
- Six male XLR connectors provide twelve output channels (or six stereo pairs).

All connections are balanced 110  $\Omega$  and transformer-isolated. Use 110  $\Omega$  AES/EBU cabling. Maximum cable length is 100m, depending on cable quality.

All connected devices must operate at the same sample rate. The engine can run on its internal clock or synchronize to one of the incoming digital formats (see MADI / Word Clock).



**WARNING** - Consumer S/PDIF signals are not directly compatible with AES3. A format converter must be used when connecting S/PDIF sources.



## NETWORK AUDIO (DANTE™ / AVB)

The two rear-panel EtherCON ports (Net 1 and Net 2) can be configured for either Dante™ or AVB operation. Dante and AVB cannot be used simultaneously.

Use Cat5e or Cat6 cabling with rugged EtherCON connectors for reliable performance.

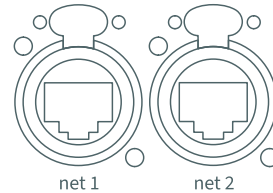

### Pinout

Pin no.	Color	Color
1	White / Orange	TP1+
2	Orange	TP1-
3	White / Green	TP2+
4	Blue	TP3-
5	White / Blue	TP3+
6	Green	TP2-
7	White / Brown	TP4+
8	Brown	TP4-

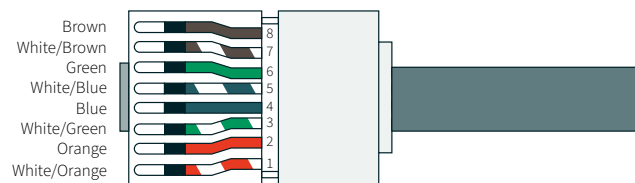

### Dante™

- Net 1 must be connected for normal Dante operation.
- Net 2 can be configured in two ways:
  - **Redundancy Mode** – Net 2 connects to a physically separate Dante network. This ensures full fault tolerance if Net 1 fails. For true redundancy, Net 2 must be routed to an independent switch and cabling path.
  - **Switched Mode** – Net 2 functions as a pass-through port, effectively acting as a built-in network switch. This allows daisy-chaining of additional Dante devices.

The operating mode of Net 2 (Redundancy or Switched) is selected in the Device Setup menu of the web interface.

**RECOMMENDATION** - Use a dedicated gigabit network switch for Dante networks. Unmanaged switches may introduce latency, dropouts, or instability and should be avoided.

**NOTE** - Dante and AVB cannot be used simultaneously and require a reboot of the networking module when switching between modes.

### AVB

When configured for AVB, both Net 1 and Net 2 operate as AVB ports.

- Connect the device to a certified AVB-compatible switch using shielded Cat5e or Cat6 cabling with EtherCON connectors.

**Note:** AVB and Dante cannot be used simultaneously and require a reboot of the networking module when switching between modes.



## MADI / WORD CLOCK

Two rear-panel BNC connectors are available for either MADI or Word Clock. Both functions cannot be active simultaneously.

Use professional-grade 75 Ω coaxial cable with precision BNC connectors.

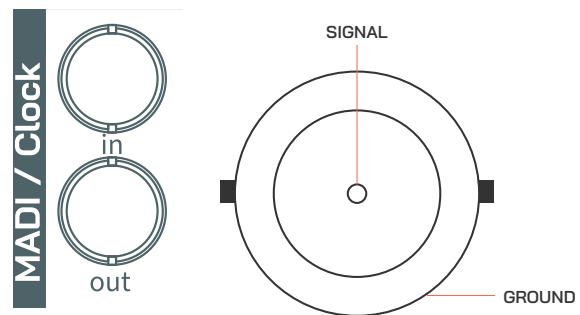

### MADI

In MADI mode, the BNC connectors operate as input/output for multichannel digital audio. Provides integration with digital consoles, routers, or recording systems.

### WORD CLOCK

When configured for Word Clock, one connector acts as input and the other as output.

## SAMPLE RATE & LATENCY

The engine supports operation at 48 kHz and 96 kHz with a resolution of 24-bit. The active sample rate is selectable in the Audio Setup menu of the web interface.

When multiple networked audio protocols are enabled, verify that all connected devices operate at the same sample rate.

## CLOCKING & SYNC SOURCE

The Upmix Engine supports both internal and external clocking.

An external wordclock can be connected to maintain stable timing across all connected digital audio devices. Using a common clock source ensures proper alignment and avoids jitter, drift, or digital artifacts when combining signals from multiple units.

Clock selection is made on the [Setup → Clocking](#). The selected source defines the system clock and sample rate.

- **Internal** – Device runs on its internal clock at 48 kHz or 96 kHz (selectable).
- **AES** – Follows the clock embedded in the AES3 input.
- **Dante** – Follows the Dante network clock (use Preferred Master if required).
- **AVB** – Follows the AVB network clock.
- **BNC (Word Clock)** – One BNC acts as input, the other as output. The device can lock to an external master or distribute its own clock.

### NOTES

- Keep runs short.
- Avoid running audio/control cables parallel to mains power.
- Before transmitting audio, verify link and sync status in the UI of the respective platform controller.
- MADI and Word Clock cannot be used simultaneously on the shared BNC connectors.



## USER INSTRUCTIONS

### power up and shutdown

#### Power Up

The unit powers on automatically when AC power is supplied to PSU1 and/or PSU2.

- There is no dedicated power switch.
- If a switch is required, use an external circuit breaker or a sequenced power distributor.
- For full redundancy, connect PSU1 and PSU2 to independent AC circuits.

#### Shutdown

No shutdown procedure is required.

Disconnect the unit from AC power to power it off.

### modes of operation

Operation of the unit can be performed via the front-panel touchscreen, the web interface, or through OSC commands over the control network.

The recommended way to operate the unit is via the web interface, as it provides the most comprehensive overview of all settings and functions.

For details on navigating the unit via the front panel or operating it through OSC commands, refer to the following chapters.

If the front panel is locked, the device can only be accessed via the web interface or OSC.

The front panel can be unlocked in the following ways:

- Via the Device Setup tab on the web interface.
- By simultaneously pressing the rotary control and touching the screen.



## access the web interface

The web interface can be accessed via any modern browser.

- Connect the front or rear control port to the network port of your computer.
- Ensure the network port of your computer is set to the same IP range as the upmix engine.
- The current IP address of the device is displayed on the front panel touchscreen.
- The default out-of-the-box IP address is set to 192.168.1.50, with subnet mask 255.255.255.0.
- Enter the IP address into your browser to enter the home screen of the interface.

You will be presented with the **Home screen**, from which you can access the various menu tabs.

### MENU TAB'S

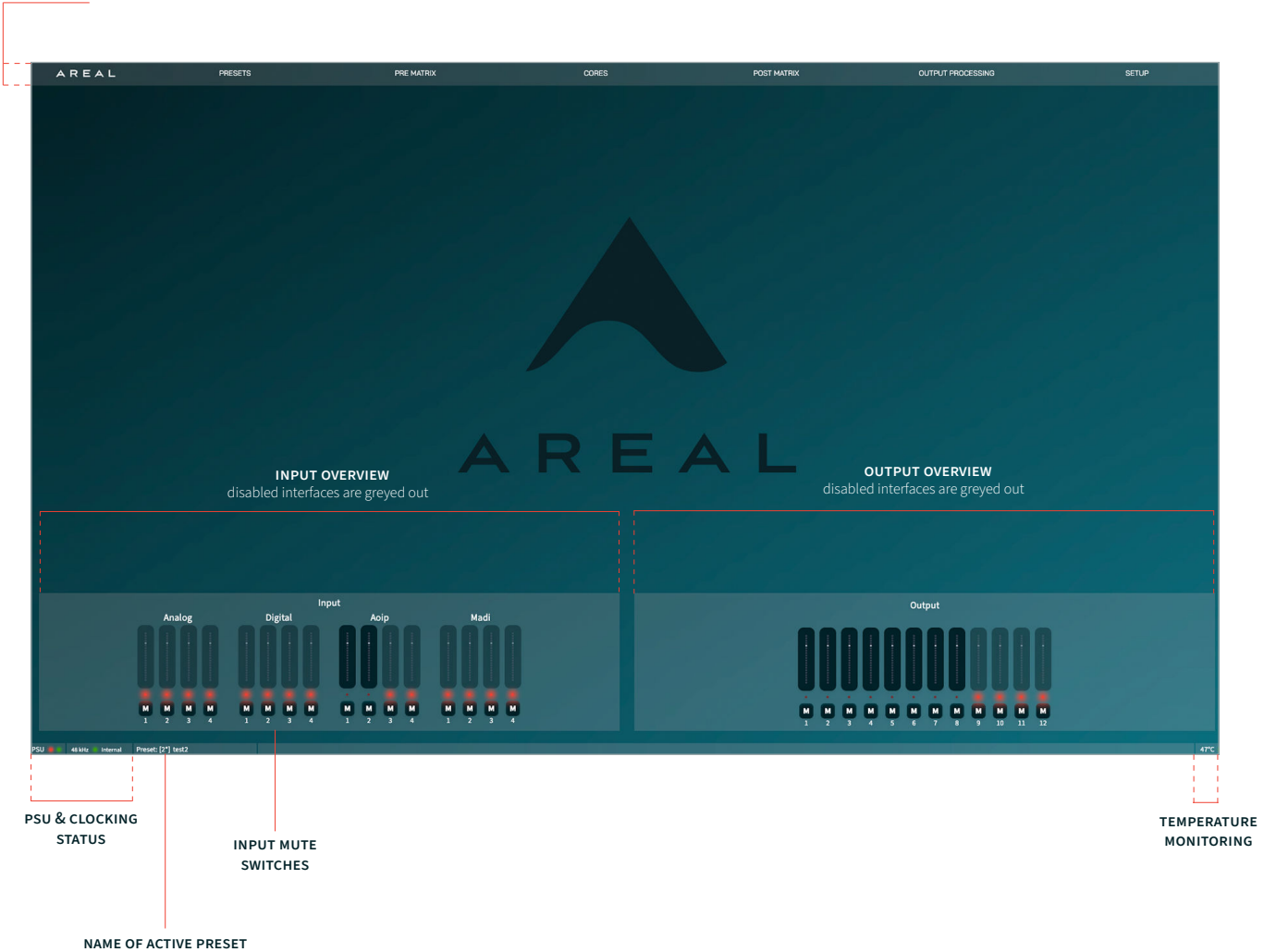

## device setup

- Navigate to [Setup](#) → [Device](#) tab.
- Give your upmix engine a name for identification in Device Alias. This name will be displayed in the web interface and on the front panel touchscreen.
- Set a manual IP address for the device, or use DHCP.
- If you change the IP address, the connection will be lost; enter the new IP address in your browser to restore access.



## audio setup

- Navigate to [Setup](#) → [Interfaces](#) tab.
- Enable the analogue and/or digital audio interfaces you will be using for your setup



**NOTE** - all 12 output channels will be active on all enabled formats.

By disabling unused formats, the pre- and post-matrices will only present the necessary information, and disabled inputs will be hidden in the input matrix to keep the interface clean.

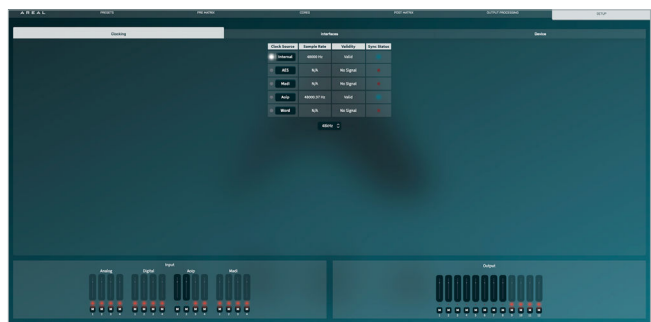

## sync source

In setups with multiple digital formats, it is recommended to choose one master clock and synchronize all other devices to it, to avoid jitter or drift.

- When using digital formats, select the clock source to sync to.

An external word clock can be provided via the BNC input.

## select cores

Navigate to the **Cores** tab to configure the processing cores. Press the **Add Cores** button to start selecting cores. The number of available slots you can use is shown below each type and depends on the available processing power. Here, you can also add the mono and stereo buses you want to use.

Some combinations you could choose include:

- Two Main Cores (for larger horizontal setups), or
- One Main Core and one Spatial Core (for three-dimensional setups with height channels).

This flexible architecture allows the system to be tailored to the loudspeaker configuration of your application.

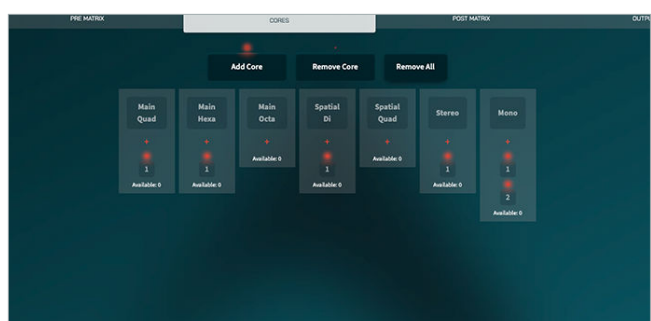

## output channel labeling

In order to streamline the routing process, it is recommended to first label your output channels.

- Navigate to the Output Processing tab.
- Assign a custom name and color to each output channel by selecting the label beneath the channel number.

The names and colors are reflected in the output matrix and the colors are also displayed in the output overview on the bottom of the interface.



## configure the pre matrix (core input)

The Pre Matrix displays available channel inputs (rows) and the bus inputs of the selected cores (columns). The core, as well as the stereo and mono bus inputs for the selected core, will be displayed here.

- Navigate to the Pre Matrix tab.
- Use the I/O matrix to route the upmixer's four input signals to the core input busses.
- Spatial cores accept only a stereo L and R input.

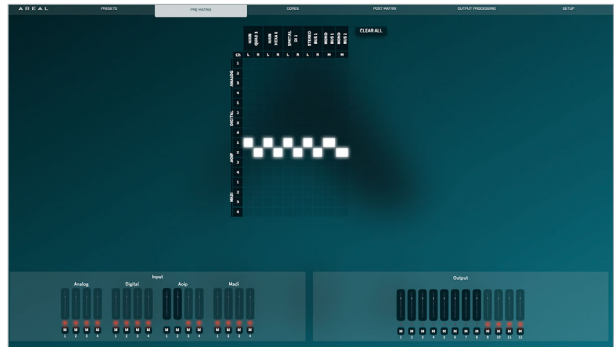

## ROUTING INSTRUCTIONS

- To route a signal, select the desired matrix window and enter a numerical value ranging from  $-\infty$  to  $+\infty$ .
- To route a signal at nominal level (0dB), enter 0. (Clicking the value while holding the Ctrl key will easily switch between 0dB and  $-\infty$ )
- To clear a value, select and delete it; the cell will then be set to  $-\infty$  (mute).
- Use the CLEAR ALL button to reset the entire matrix.

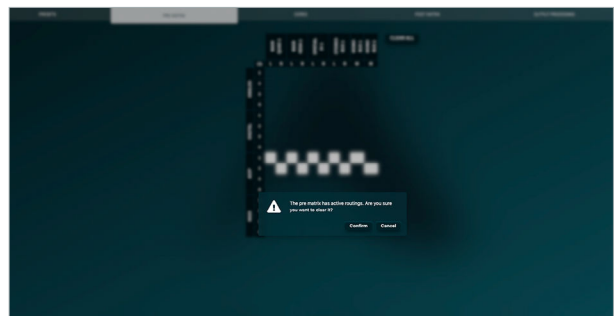

## RECOMMENDED SETTINGS

- Route stereo Left input → all core Left inputs and to the stereo bus Left input.
- Route stereo Right input → all core Right inputs and to the stereo bus Right input.
- For mono busses (e.g. subs or center), route both Left and Right inputs at  $-6$  dB to the mono bus, these will be summed to 0 dB.



## configure the post matrix (core output)

The Post Matrix displays available core outputs (rows) and device outputs (columns). Only the outputs of the enabled cores are displayed.

- Navigate to the Post Matrix tab.
- Route the core outputs to the device outputs (to which your speakers are connected) by entering values in the matrix cells.

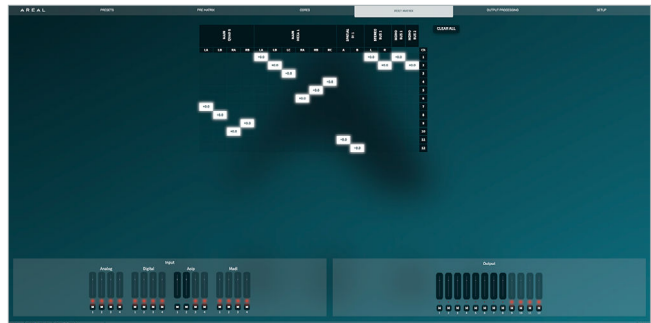

### RECOMMENDED SETTINGS

- Route the core's Left A/B/C/D outputs to separate left loudspeakers with overlapping coverage.
- Route the core's Right A/B/C/D outputs to separate right loudspeakers with overlapping coverage.
- (Optional) Blend the stereo bus L into the front left loudspeakers and stereo bus R into the front right loudspeakers to adjust the level of immersiveness and restore parts of the original stereo image.
- Route the mono bus outputs to subwoofers or a center loudspeaker.

## output processing

Each output channel includes the following processing functions:

- Focusfield (Focus/Diffuse configuration)
- 6-band parametric EQ, including high-pass and low-pass filters
- Gain ( $-\infty$  to +18 dB)
- Delay (up to 1000 ms)
- LF Warping (phase controlled sub arcing)
- Polarity inversion
- Mute

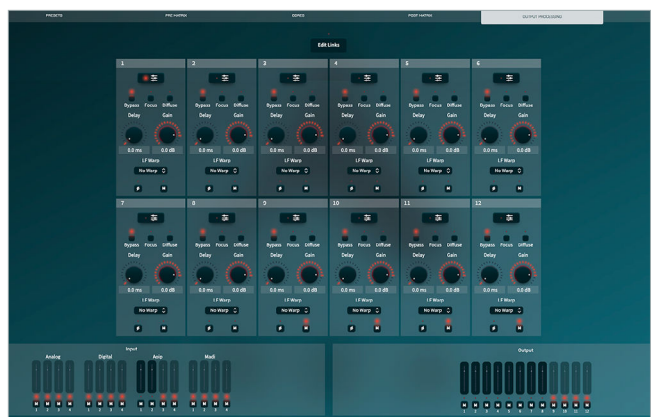

## focusfield

The Focus/Diffuse function allows you to shape how the immersive sound field is perceived by the audience. Loudspeakers set to Focus create a more defined and directional image, while loudspeakers set to Diffuse contribute to a wider and more enveloping atmosphere.

**Example:** In a 4.1 setup, assign the two front loudspeakers to Focus to draw the listener's attention forward, while setting the two rear loudspeakers to Diffuse to create an immersive backdrop.

## lf warping

LF-Warping is designed for situations where subwoofers are positioned directly beneath the main speakers and a sub-arc configuration is required. Instead of delaying the subwoofers — which could cause time misalignment with the mains — LF Warping applies a controlled phase rotation to the subs on the lower frequencies (200Hz and below). This allows you to create a sub-arc while maintaining proper timing between the subwoofers and the main system.

## preset management

The Upmix Engine provides 20 preset slots arranged in two columns:

- **Default Presets** (left column, 10 slots)  
These factory presets include commonly used loudspeaker configurations. Default presets serve as starting points for system setup and cannot be modified or deleted.
- **User Presets** (right column, 10 slots)  
These slots are available for storing your own configurations. To create a user preset, first load a suitable default preset, make the required adjustments, and then save it to an available user slot.

### Active Preset

The active preset is always displayed at the bottom of the interface, including the slot number and the preset name. Any unsaved changes to the active preset are indicated with an asterisk (\*) after the preset name.

### Preset Controls

- **New** – Creates a new user preset in a selected empty slot.
- **Load** – Activates the selected preset. The system configuration changes immediately to match the loaded preset.
- **Save** – Stores the current configuration into the selected user slot, overwriting any existing content.
- **Lock/Unlock** – Locks the selected preset to prevent accidental changes. Locked presets are indicated by a padlock icon and cannot be overwritten, renamed, or deleted.
- **Rename** – Renames the selected preset for easier identification.
- **Delete** – Removes the selected preset from the slot (only available for user presets).
- **Export** – Saves a selected user preset to an external file for backup or transfer to another device.
- **Import** – Loads a preset file from external storage into an empty user slot.



## info & monitoring

The Info tab provides real-time system monitoring and diagnostic information for the Upmix Engine. This section allows the operator to verify performance, identify issues, and ensure reliable operation in critical environments.

### TEMPERATURE

The temperature of each internal module is monitored in real time, including both DSPs, the system-on-module (SOM), and individual boards. Graphs display current and historical temperature trends, while peak values are listed numerically. The Reset Peaks button clears the stored maximum readings.

**VERSION & SYSTEM INFORMATION** - The version panel provides detailed information on firmware and software versions currently installed, including:

- UI and controller firmware versions
- DSP firmware versions

This information is essential for technical support and troubleshooting



**NOTE** - Always provide the serial number and firmware versions when contacting Areal support.



## SETUP EXAMPLES

This chapter illustrates common system configurations for the Upmix Engine. Each example highlights typical use cases, recommended loudspeaker layouts, and signal routing approaches. The goal is to provide a practical reference for system engineers when deploying the device in different environments.

### EXAMPLE - 4-frontal immersive setup

- **Application:** Theatres, corporate AV, small venues.
- **Configuration:** One Main Quad Core. Stereo L/R split into LA/LB and RA/RB.
- **Loudspeaker Layout:** Four frontal loudspeaker positions across the front stage with overlapping coverage.
- **Result:** Creates a wider and more enveloping frontal image while maintaining clarity and localization.

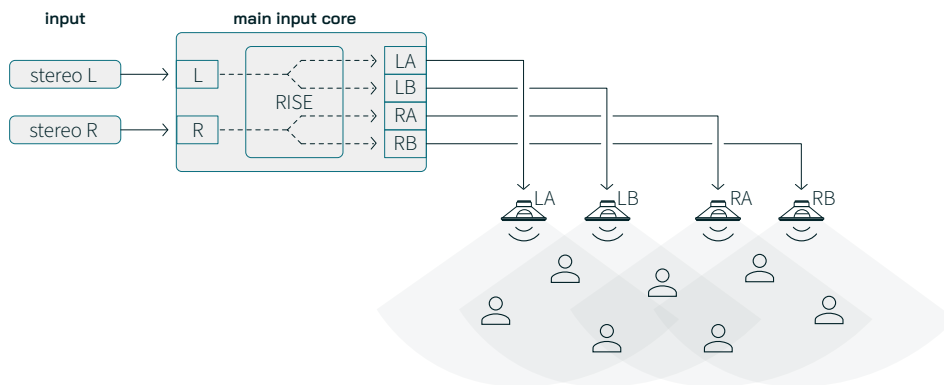

### EXAMPLE - hexa frontal with quad delays

- **Application:** Festivals, large outdoor events or venues.
- **Configuration:** Main Hexa Core for six frontal loudspeaker positions combined with a Quad Core assigned to four delay positions.
- **Loudspeaker Layout:** Six front positions plus four delay positions further back.
- **Result:** Extends immersive coverage into the audience field with coherent imaging in both main and delay zones.

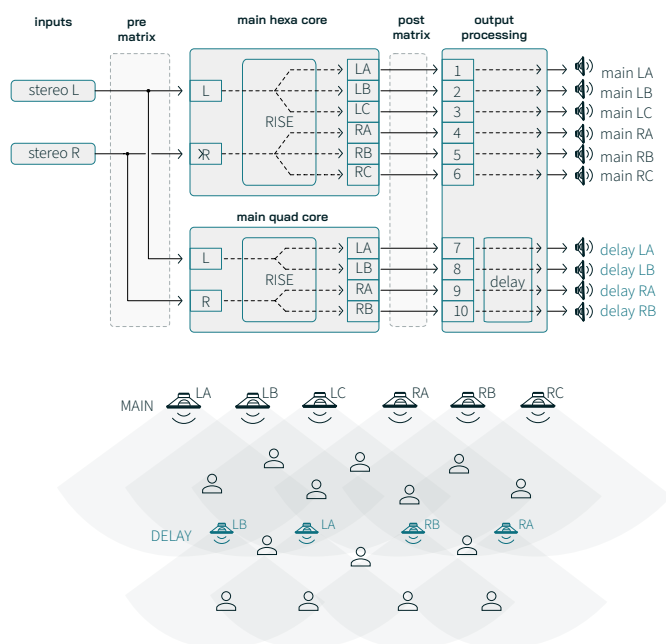

### EXAMPLE - small 270° coverage with octa core

- **Application:** Small to medium venues.
- **Configuration:** Main Octa Core. Stereo channels split into LA/LB/LC/LD and RA/RB/RC/RD.
- **Loudspeaker Layout:** Eight loudspeaker positions distributed in a 270° arc.
- **Result:** Provides a natural surround experience. Overlapping coverage ensures listeners perceive all A, B, C, D versions as one fused immersive field.

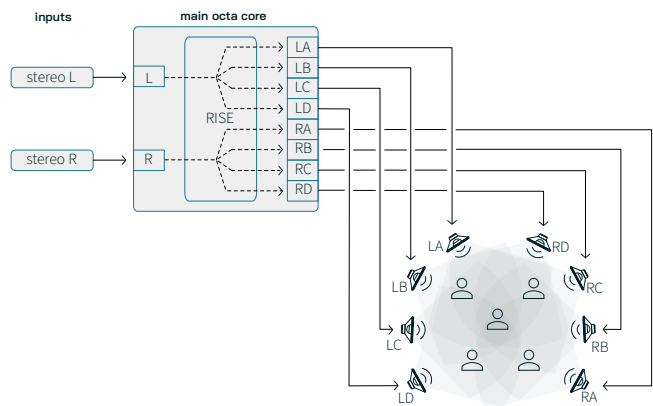

✓ **TIP** - On the right side, changing the order of RA to RD can enhance the result, as listeners are more equally exposed to the different A-D signal versions.

### EXAMPLE - large 270° coverage with hexa core

- **Application:** Large festival areas and venues.
- **Configuration:** Main Hexa Core driving six decorrelated outputs (LA, LB, LC, RA, RB, RC) distributed across eight loudspeaker positions.
- **Loudspeaker Layout:** Eight loudspeaker positions arranged in a 270° arc to cover a large audience area.

In larger venues, not all audience members will be equally exposed to both front and rear positions. Audiences at the front may not clearly hear the rear positions, while those at the back may not hear the front positions.

To maintain coherence, the rear loudspeaker positions should therefore reproduce the same signal versions as the two front positions. This ensures that every listener is exposed to the full A, B, and C signals, regardless of their position in the audience area.

In this case, the order of the right side has been altered for better results, while the two front positions reproduce the same signals as the two rear positions to ensure overlapping.

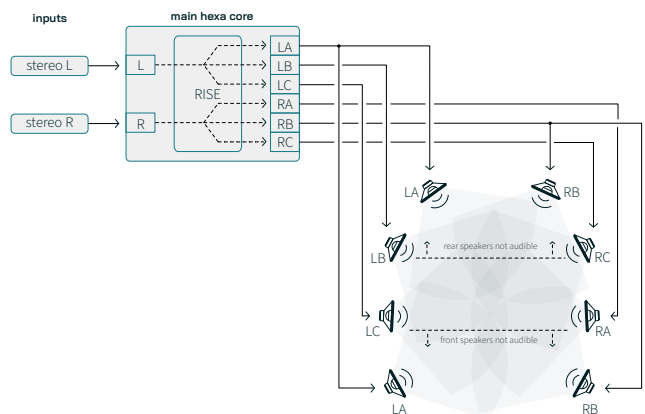

## EXAMPLE - 5.1 surround with center, subwoofer and focusfield enabled

- **Application:** Cinema, broadcast rooms, or installations requiring familiar 5.1.
- **Configuration:** Quad Core plus mono buses for Center and Subwoofer.
- **Loudspeaker Layout:** L/R front in Focus mode, L/R rear in Diffuse mode, plus dedicated center and sub positions.
- **FocusField:** By setting the front positions to Focus and the rear positions to Diffuse, the perceptual illusion is created that the sound originates from the front, while still maintaining an immersive spatial field.
- **Result:** Stable frontal imaging for dialogue or lead instruments, combined with immersive depth and controlled low-frequency reinforcement.

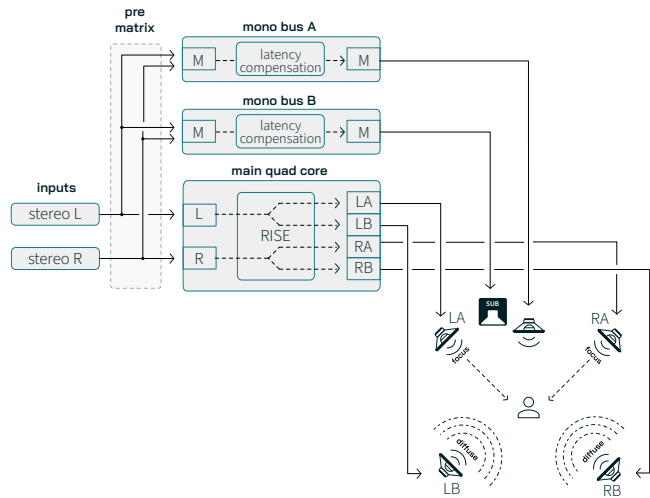

**NOTE** - In this example, two separate mono buses are used for the center and subwoofer. However, one mono bus can also be shared for both if required.

## EXAMPLE - 7.1.4 with main hexa, spatial quad, center and lfe

- **Application:** Cinemas and immersive touring productions requiring full three-dimensional coverage.
- **Configuration:** Main Hexa for the horizontal layer, Spatial Quad for four overhead positions, plus a mono bus for Center and LFE.
- **Loudspeaker Layout:** Six horizontal loudspeaker positions (LA–RC) combined with a dedicated center and four spatial overhead positions. An additional LFE position extends the setup. The order of the A–C signals has been alternated to enhance the immersive effect.
- **Result:** The horizontal layer provides frontal and surround imaging, while the spatial layer adds a convincing vertical dimension. The center position anchors dialogue or lead content, and the LFE enhances low-frequency effects.

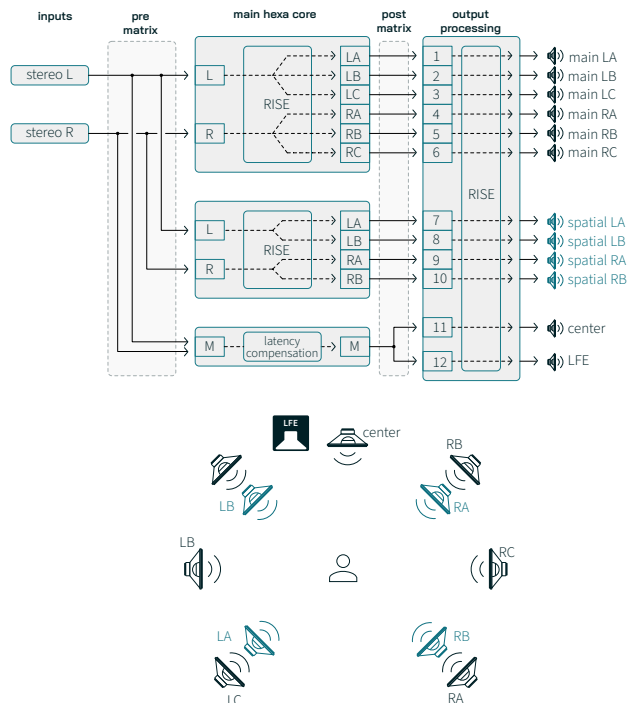

**NOTE** - In a Dolby application, the LFE channel should be used only as an enhancement for low-frequency effects, not as the primary bass source. For music applications, Dolby recommends leaving the LFE unassigned unless specific low-frequency effects are required.



## SOURCE EXAMPLES

### EXAMPLE - DJ + vocal

- **Application:** Clubs, festivals, and live shows where music is combined with live vocals or MCs.
- **Configuration:** Stereo DJ source (L/R) and vocal input routed to the Spatial Quad Core. In parallel, the DJ source is also sent to the Stereo Bus, and the vocal to a Mono Bus.
- **Loudspeaker Layout:** Spatial Quad outputs distributed across four immersive positions, with a dedicated center position for the vocal.
- **Result:** The stereo bus can be blended with the spatial outputs to fine-tune the level of immersiveness while retaining elements of the original stereo image. The vocal routed via the mono bus ensures stable localization and intelligibility within the immersive mix.

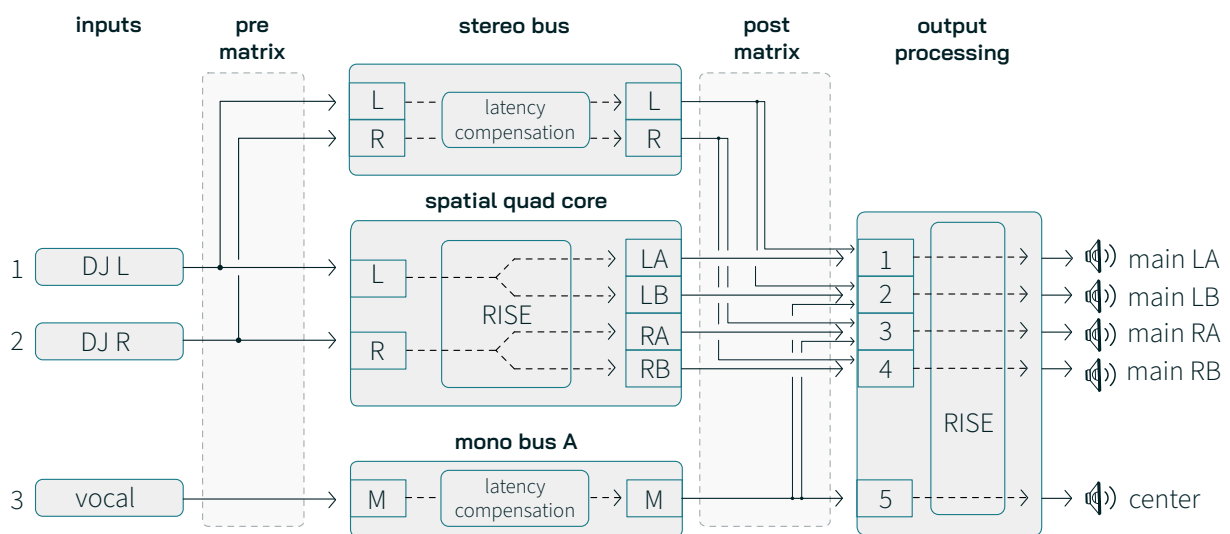

## TECHNICAL SPECIFICATIONS

<b>Specification</b>	<b>Value</b>
Input voltage	100-240 VAC
Max. Input Power	2x 50W
Fuse	3.15A
Power consumption	32W
Operating Temperature	-20°C to 40°C
Storage Temperature	-10°C to 50°C
Transport Temperature	-10°C to 50°C
Relative Humidity	10%–90%, non-condensing
Storage Relative Humidity	10%–90%, non-condensing
Transport Relative Humidity	10%–90%, non-condensing
Dimensions (w x d x h)	482 × 220 × 44 mm
Weight including packaging	~3.5 kg (7.72 lbs)
Net Weight	~3.9 kg (8.59 lbs)
Use environments	Indoor use only
Max. altitude	2000 m
Appliance class	Class I
Pollution degree	2
Overvoltage category	OVII



## SAFETY & SYMBOLS

### general safety instructions

Read all safety instructions carefully before installing or operating the Upmix Engine. Improper use may result in electric shock, fire, injury, or damage to the unit.

- Only qualified personnel may install or service the device.
- Do not operate the unit near water or in environments exposed to moisture.
- Do not place objects filled with liquids (such as vases or bottles) on or near the unit.
- Ensure proper ventilation at all times. Do not block the air inlets or outlets.
- Do not install the device near heat sources such as radiators, stoves, or amplifiers.
- Use only the supplied power cables and ensure the device is properly grounded.
- Disconnect the unit from AC mains before cleaning or servicing.
- Never remove the top cover. There are no user-serviceable parts inside. Servicing must be carried out by authorized personnel.
- Protect all power and signal cables from physical stress or damage.



**WARNING** - High sound pressure levels may cause permanent hearing damage. Always comply with local regulations regarding maximum sound levels and exposure times.

### electrical safety

- Mains voltage: 100–240 V AC, 50/60 Hz.
- Use only the supplied IEC power cables.
- Connect each PSU to an independent AC source for redundancy.
- Ensure that the unit is connected to a properly grounded outlet.
- The AC mains plug shall remain accessible for quick disconnection in case of emergency.

The intended use of this product is to convert stereo to immersive in real-time.

Instructions for installation, operation, cleaning, and maintenance as described in this document must be followed. Disconnect the power and Ethernet cable when performing maintenance and cleaning.

The cover shall never be removed from the instrument.

The instrument must be installed on a stable and flat table or bench which is able to withstand a minimum load of 50 kg, in a dust and dirt-free environment free from dust and dirt and according to the environmental specifications (see technical specifications chapter).

Do not allow liquids to enter the interior of the instrument. Protect the instrument against accidental spillages and splashes. Clean up spillages immediately. Do not operate the instrument if liquids have entered the instrument.



The user shall be responsible for any malfunction resulting from improper use, maintenance, repair, damage, or alteration by anyone other than Areal or its certified partners. Certification can be awarded by successfully completing the Areal accredited Technical Training.

The Areal Upmix Engine must be repaired and serviced in accordance with written instructions issued by Areal and must not be altered in any way without written approval of Areal.

If the Areal Upmix Engine is defect, it should not be used. Disconnect the unit from the power outlet and parts that are broken, missing, worn, distorted or contaminated should be replaced.

All safety labels and safety markings shall be kept clean and legible. Inspect the safety labels and safety markings and replace them if not legible or identifiable from a safe viewing distance. Contact Areal for replacement labels.

It is the user's responsibility to take measures to ensure that the working environment is confirm EMC requirements of the Areal Upmix Engine device. The "EMC Declaration" is available on request.

When installing the Areal Upmix Engine, take caution because of the risk of electric shock.

Use this product only in a sheltered indoor environment. Do not expose the unit to rain, dust, moisture, or direct sunlight. Cables may be routed outdoors for temporary installations provided that suitable outdoor-rated cables are used and adequately protected.

Provide an easily accessible circuit-breaker with contact separation of at least [3 mm], with a fuse range of [6 A].

Operation, care and maintenance work may only be performed by the operator or user as described in this user manual.

If there is any indication of damage or defects, do not open and attempt to repair the Areal Upmix Engine yourself; call in a skilled person.

Repairs may only be carried out by a skilled person using original spare parts and accessories.

Power the device from a power outlet with protective earth only.

The instrument is a Class I electrical device and requires the protective earth pin to be available and connected to the power outlet connector. Only use the connector cables supplied with the instrument.

The instrument should only be operated from a power source that meets the specifications mentioned in the product's electrical label. Only use the supplied power cable included in the delivery. When the supplied power cable is broken, replace the cable with an identical cable as specified in the accessories chapter or contact Areal.

Do not use extension cords or power strips. Do not overload an electrical outlet.

The mains power outlet should be within easy reach, maximum 1,5 m.



The Ethernet connection should be located within a maximum of 3 m.

Children are not allowed to play with the Areal Upmix Engine.

Service is guaranteed until 1 year after EOL of the product.

The expected service life is 10 years.

### symbols



Consult manual before use



Warning sign



Caution is needed when installing and using this device, consult the manual before use



Indoor use only



Alternating Current (AC)



Networking interface.



CE marking



Location of manufacturing



Recycling



Caution, risk of electric shock



Multiple power sources



Read the manual



Manufacturing date



Country of manufacturing



FCC certificate marking (US)



UKCA marking

## TROUBLESHOOTING

### reset procedure

Power-cycle the unit by disconnecting mains for 10 seconds and reconnecting.

### contact support

If issues persist, contact your local point of sales.



In case of device failure or error alerts, discontinue use immediately and contact technical support for assistance.

## MAINTENANCE, CLEANING & DISPOSAL

### cleaning instructions

Always disconnect the unit from the mains before cleaning. Use a soft, damp cloth with mild detergent. Do not use solvents or abrasive cleaners. Prevent liquids from entering the device; if liquid has entered, do not power on the unit and contact service support.

### periodic inspection

Regularly check all power and signal cables, connectors, and ventilation openings. Ensure that labels and safety markings remain legible. Replace damaged or missing labels immediately. Verify that airflow is not obstructed and that dust is removed from vents.

### service & maintenance interval

The Upmix Engine contains no user-serviceable parts. Yearly inspection and maintenance must be carried out by qualified service personnel. Only original spare parts and accessories should be used. Service support is guaranteed until 1 year after the product's official end-of-life (EOL).

### disposal



This product is designed with high-quality recyclable components. Dispose of it according to your local regulations for electronic waste.

Proper disposal prevents potential environmental and health risks



## REGULATORY & COMPLIANCE

### **ce, fcc, rohs**

This device complies with CE and RoHS regulations.  
Documentation can be requested on [support@areal.world](mailto:support@areal.world).

### **emc declaration**

This device complies with EMC declaration available upon request.



### **disposal**

Dispose according to local WEEE and e-waste regulations.

## APPENDICES

### open source licenses

Areal BV uses Open-Source software in some of its products, including software licensed under the GNU General Public License ("GPL"). Most open-source packages are used unmodified as binaries, but where required, Areal BV has modified the open-source package to perform the functions required for the Upmix engine product. Areal BV makes the open-source software and any modifications available consistent with the terms of the GPL and LGPL regardless of whether those licenses apply. The code made available by Areal BV is for informational purposes only and distributed "As is" with no support and/or warranty of any kind intended, implied, or provided.

To request the open-source package, contact [support@areal.world](mailto:support@areal.world).

### disclaimer

Copyright © 2026 Areal and/or its affiliates. All rights reserved. No part of this user manual may be reproduced, stored in a retrieval system, transmitted, published, or distributed in any form or by any means, electronically, mechanically, by photocopying, microfilming, recording, or otherwise, without the prior written consent of Areal; however, notwithstanding the foregoing, the owners of the Areal SR1 may make copies solely for purposes of training personnel in the use and servicing of the unit within their business or organization. Maximal care has been taken by Areal in the preparation of this user manual. However, Areal shall not be liable for any technical or editorial errors or omissions contained herein or for incidental or consequential damages in connection with the furnishing, performance, or use of this document. The information in this document is provided "as is" without warranty of any kind, and is subject to change without notice. Areal SR1 and the Areal logo are either registered trademarks or trademarks of Areal and/or its affiliates in various countries worldwide. All other trademarks mentioned in this document are the property of their respective owners and are used for identification purposes only.

---

## CONTACT

### AREAL BV

Hoek 76 unit 200  
2850 Boom  
Belgium

[support@areal.world](mailto:support@areal.world)

[www.areal.world](http://www.areal.world)

---



